



Productos de instrumentación

Adaptador de brida



Adaptador de brida

Descripción del producto

Los adaptadores de brida Schneider se emplean como eslabón entre la tubería y los instrumentos. Esta construcción compacta no necesita ninguna otra pieza de conexión.

Características

Conexión 1 (Conexión de brida)

- Brida ASME desde 1/2" hasta 3" y desde Class 150 hasta 2500
- Brida DIN y EN desde DN15 hasta DN80 y desde PN10 hasta PN100
- Todas las superficies de obturación corrientes
- Otros diámetros nominales y niveles de presión a petición
- Conexiones de brida conforme a API, JIS o ISO a petición

Conexión 2

- Racor de anillo cortante DIN 2353
- Modelo de rosca
- Racor con anillo de sujeción

Materiales

- Brida ASME A105 o 316/316L
- Brida DIN/EN 1.0460 o 1.4571

Opciones

- Materiales conforme a NACE MR0175 / ISO 15156
- Modelo sin aceite ni grasa para oxígeno
- Certificado de inspección conforme a EN 10204

Otros modelos a petición.

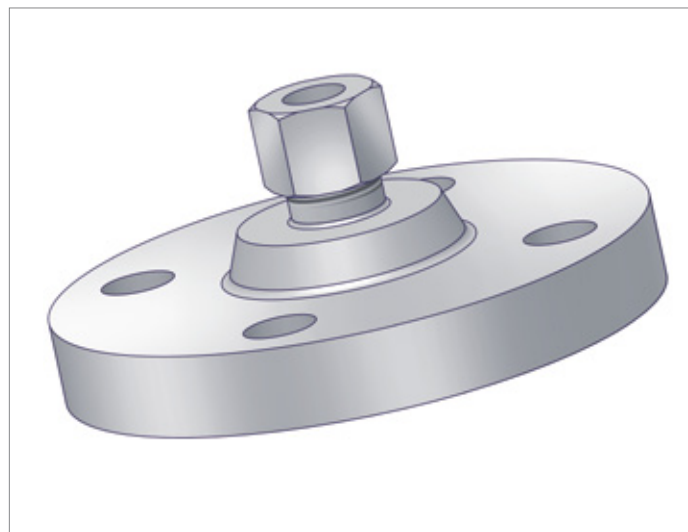

FAN-QLDG14-P

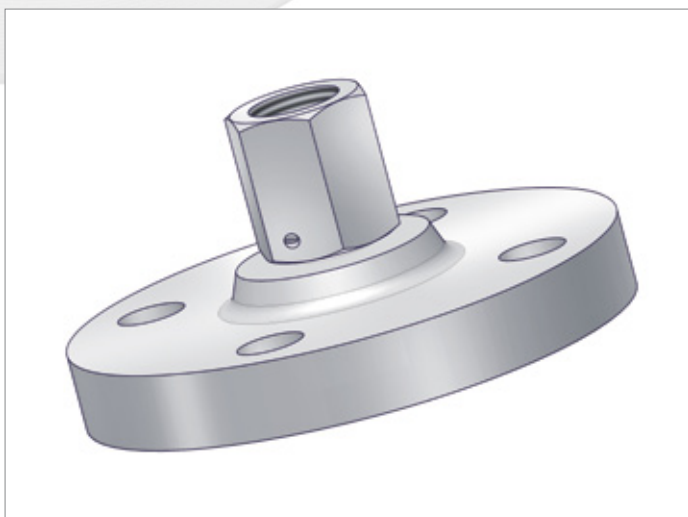

FAN-QLDLGQ-P

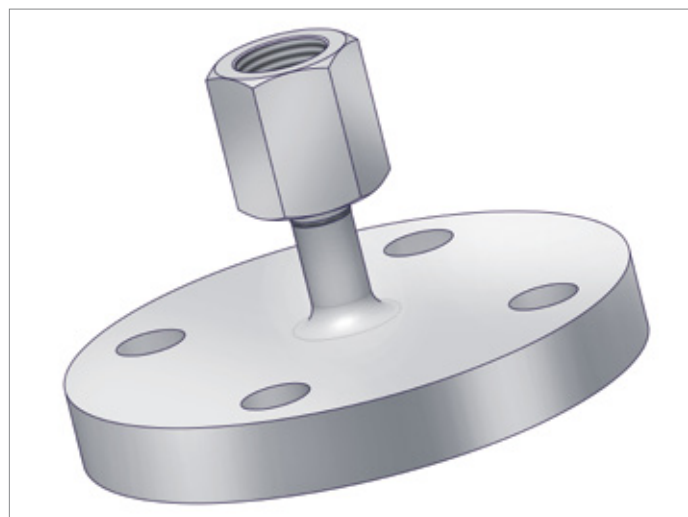

FAN-QLDLGD-P

Información de pedido | Adaptador de brida

		1	2	3	4	5	6	7	8	9	10	11	12	13	14
		F	A	N	-	N	A	A	G	1	4	-	C		
Adaptador de brida															
Brida															
N	Brida ASME														
P	Brida DIN														
Q	Brida EN														
Conexión 1 (Conexión de brida)															
Brida ASME		Brida DIN				Brida EN									
A	1/2" RF	DN15 C	DN15 B1												
D	3/4" RF	DN15 F	DN15 C												
F	3/4" RTJ	DN20 C	DN20 B1												
G	1" RF	DN20 D													
L		DN25 C	DN25 B1												
N	2" RF	DN25 E	DN25 B2												
Q	2" RTJ	DN25 N	DN25 D												
U	3" RF	DN40 F	DN40 C												
W	3" RTJ	DN50 C	DN50 B1												
Z		DN80 C	DN80 B1												
Brida ASME		Brida DIN / Brida EN													
A	Class 150	PN 10													
B	Class 300	PN 16													
C	Class 600	PN 25													
D	Class 900	PN 40													
E	Class 1500	PN 63													
F	Class 2500	PN 100													
Conexión 2															
G14	Racor con anillo cortante DIN2353 12S														
G15	Racor con anillo cortante DIN2353 14S														
LGB	Manguito giratorio G1/4 (soldado)														
LGD	Manguito giratorio G1/2 (soldado)														
LGN	Manguito giratorio G1/4														
LGQ	Manguito giratorio G1/2														
	Racor con anillo de sujeción														
Material															
Brida ASME		Brida DIN / Brida EN													
C	A105	1.0460													
P		1.4571													
S	316L														
Opciones															
B	Sin aceite ni grasa para oxígeno														
N	NACE MR0175/ISO 15156														



**Armaturenfabrik Franz Schneider
GmbH + Co. KG**

Bahnhofplatz 12
74226 Nordheim
Deutschland/ Alemania

Tel:

+49 71 33 101-146 Venta en Alemania
+49 71 33 101-129 Venta fuera de Alemania

Fax:

+49 71 33 101-148 Venta en Alemania
+49 71 33 101-180 Venta fuera de Alemania

www.as-schneider.com



Fábrica 1 en Nordheim

Fábrica 2 en Nordheim | Fábrica en Rumanía