

butt weld

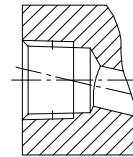

NPT

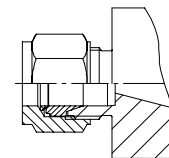

compression fitting

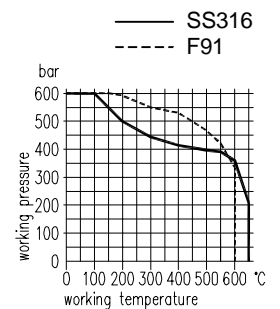
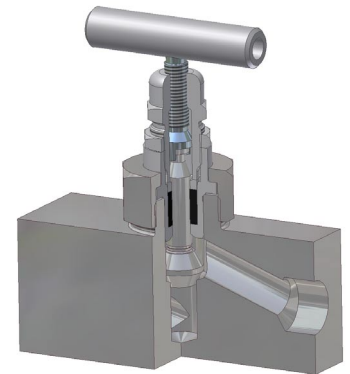

Connections		Body material	
		SS316	F91
Inlet	Outlet	Part no.	
14mm socket weld	14mm socket weld	A1B-EEAEEA-SAK	A1B-EEAEEA-WAK
16mm socket weld	16mm socket weld	A1B-EFAEFA-SAK	A1B-EFAEFA-WAK
16mm socket weld	14mm socket weld	A1B-EFAEEA-SAK	A1B-EFAEEA-WAK
25 x 5,5mm butt weld	14mm socket weld	A1B-CKEEEA-SAK	A1B-CKEEEA-WAK
25 x 5,5mm butt weld	16mm socket weld	A1B-CKEEFA-SAK	A1B-CKEEFA-WAK
25 x 5,5mm butt weld	25 x 5,5mm butt weld	A1B-CKECKE-SAK	A1B-CKECKE-WAK
1/2" pipe socket weld	1/2" pipe socket weld	A1B-D4AD4A-SAK	A1B-D4AD4A-WAK
1/2 NPT female	1/2 NPT female	A1B-LN4LN4-SAK	A1B-LN4LN4-WAK
14mm compression fitting	14mm compression fitting	A1B-H25H25-SAK	A1B-H25H25-WAK
16mm compression fitting	16mm compression fitting	A1B-H26H26-SAK	A1B-H26H26-WAK

Components	Material 316	Material F91
Body	316H	F91
Needle tip	1.4571	1.4923 / Stellite 6
Valve stem	1.4923	1.4923
Bonnet	1.4401	F91
Union nut	1.4571	1.4571
Packing	graphite	graphite
Gland	316	316
Stem nut	1.4301	1.4301
Lock nut	1.4305	1.4305
T-handle	1.4305	1.4305
Set screw	A2-70	A2-70

- Non-rotating valve tip
 - Metal to metal backseat
 - Flanged bonnet
 - External stem thread
 - Back seat design
 - Non rotating needle tip
- Optional:
- NACE MR0175
 - Oxygen service
 - Valve tip in Stellite
 - Inspection certificate 3.1 acc. to EN10204
 - Special materials