

ISO 15848 versus TA-Luft:

AS-Schneider 5 valve manifold from the ISO FE Series

TA-Luft is well-known in the German and European processing industries as the guarantee for high-quality stem sealings. But what guarantee do customers get from TA-Luft compliant Industrial Valves and what's behind the ISO 15848 standard?

Pictures by: Armaturenfabrik Franz Schneider GmbH + Co. KG

By Markus Häffner, Armaturenfabrik Franz Schneider GmbH + Co. KG

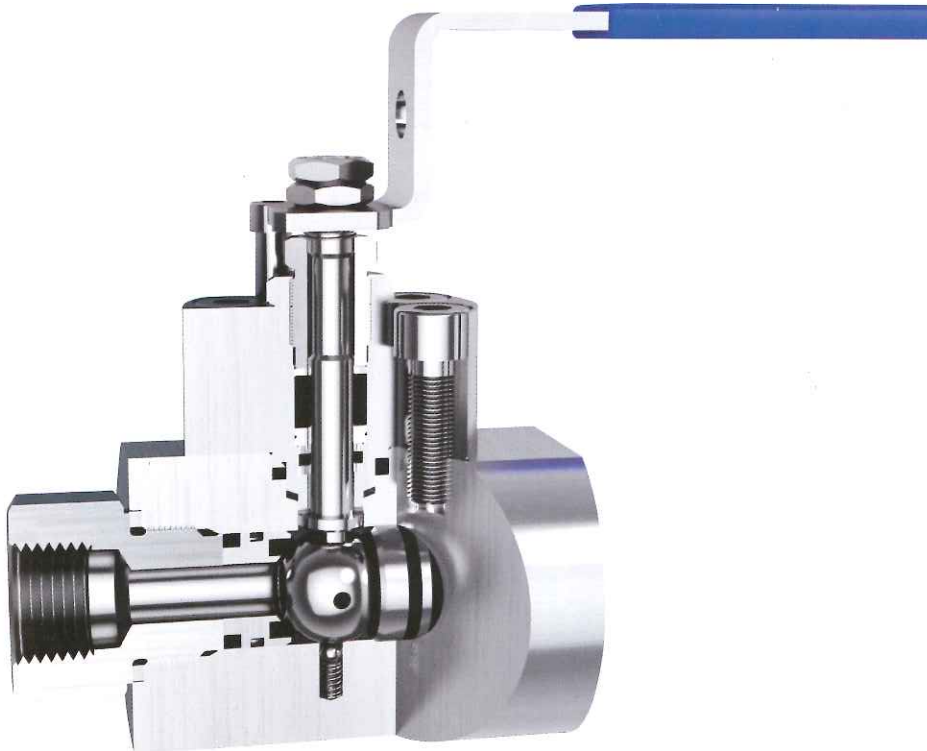

AS-Schneider Ball Valves are available for a pressure rating of 420 bar / Class 2,500

TA-Luft

TA-Luft is the first general management specification to the German Federal Pollution Control Act (Technical Guideline for Air Pollution Control – TA-Luft). It was published on 30 July 2002 and came into force on 1 October 2002. The document, which comprises 239 pages, only mentions sealing of stem passages in Chapter 5.2.6.4.

According to this, TA-Luft is considered to be complied with if metal bellows with

a downstream safety packing or similar sealing systems; in this connection, the equivalence in the verification system must be confirmed in accordance with VDI 2440 (November 2000 issue).

VDI 2440 deals with the sealing system of the stem/shaft seal but not the complete industrial valve. The problem of the inspection according to TA-Luft/VDI 2440 is that important inspection requirements such as the number of switching cycles and the thermal cycles are not specified



AS-Schneider E Series Needle Valves and Manifolds with Screwed Bonnet are high wear resistant and equipped with a hard coated stem thread. The non-rotating stem guarantees low actuating forces and minimum wear of the sealing elements. Pressure rating 420 bar / Class 2,500.

in concrete terms. Specification like "... in the case of pressures and temperatures and stem or shaft movements that cover the operating conditions..." allow a great deal of scope for carrying out the inspection. Specialists also often interpret these specifications in different ways. For customers who just want to verify that TA-Luft has been complied with, this means that the following questions are unanswered: How many switching cycles were carried out, were thermal cycles carried out and if so, how many? This means that a direct comparison of TA-Luft industrial valves is not possible. As a result, it is only possible to recommend having the corresponding inspection report presented.

FUGITIVE EMISSIONS

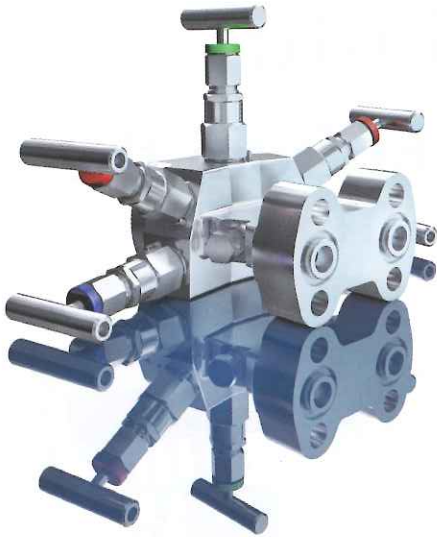

Safety at the highest level: AS-Schneider's ISO FE Series meets the stringent requirements of ISO 15848 and also has Fire Safe approval.

Apart from this, many seal manufacturers like to advertise with "TA-Luft packings". Simply using "TA-Luft packings" of this type, does not guarantee long-term leak tightness. Too many other factors play a

significant role in a sealing system. These include, for example, the stem surface condition and the gap dimensions between the gland and the stem. With a packing like this, you hope, at best that using it will mean that an industrial valve will comply with the requirements of TA-Luft. However, this must still be verified in a test.

ISO 15848

ISO 15848 entitled "Industrial Valves - Measurement, test and qualification procedures for fugitive emissions" consists of two parts:

- Part 1: Classification system and qualification procedures for type testing of Industrial Valves
- Part 2: Production acceptance test of Industrial Valves

By contrast with TA-Luft, this standard does not just consider the sealing system of the stem/shaft seal; rather, it takes into account the entire Industrial Valve including the housing seals. Due to a type test, the Industrial Valve is classified into the following performance categories:



Bellows Sealed Valves by AS-Schneider – the "technically leakproof" solution.

Tightness class/endurance class/temperature class.

Specifying an Industrial Valve according to ISO 15848 provides the following benefits for purchasers:

Example: AS-Schneider ISO FE Type 2	ISO FE	A	H	- CO2	- SSA1	- t(-29°C, 200°C)	- PN 420	- ISO 15848-1
Tightness class								
A $\leq 10^{-6} \text{ mg} \cdot \text{s}^{-1} \cdot \text{m}^{-1} = 1,32 \cdot 10^{-7} \text{ mbar} \cdot \text{l/s}$ (Stem- $\varnothing 7,5\text{mm}$)								
B $\leq 10^{-4} \text{ mg} \cdot \text{s}^{-1} \cdot \text{m}^{-1} = 1,32 \cdot 10^{-5} \text{ mbar} \cdot \text{l/s}$ (Stem- $\varnothing 7,5\text{mm}$)								
C $\leq 10^{-2} \text{ mg} \cdot \text{s}^{-1} \cdot \text{m}^{-1} = 1,32 \cdot 10^{-3} \text{ mbar} \cdot \text{l/s}$ (Stem- $\varnothing 7,5\text{mm}$)								
Test fluid								
H Helium gas - Tightness class AH, BH, CH								
M Methane gas - Tightness class AM, BM, CM								
Endurance classes (mechanical and thermal cycles)								
Isolation valves								
CO1 = 500 mechanical / 2 thermal cycles								
CO2 = 1,500 mechanical / 3 thermal cycles								
CO3 = 2,500 mechanical / 4 thermal cycles								
Control valves								
CC1 = 20,000 mechanical / 2 thermal cycles								
CC2 = 60,000 mechanical / 3 thermal cycles								
CC3 = 100,000 mechanical / 4 thermal cycles								
Number of stem seal adjustments								
SSA 0 = None, SSA 1 = One adjustment, SSA 2 = Two adjustments A maximum of one adjustment is accepted for CO1, two for CO2 and three for CO3								
Temperature class								
Qualified temperature range								
Test pressure								
According to PN or ASME Class rating								

Table: Designation/markings of an Industrial Valve qualified according to ISO 15848-1.

- Industrial Valves made by different manufacturers can be directly compared on the basis of the classification.
- The complete Industrial Valve meets the requirements. This also applies in particular to the highly loaded stem thread with needle valves. TA-Luft only deals with the sealing system of the stem passage.
- The specified mechanical and thermal load cycles ensure that the sealing elements demonstrate adequate leak tightness even after several heating and cooling phases.
- Tightness class "A" allows a leak rate

that is lower by a factor of ten than with TA-Luft at temperatures of less than 250 °C

Industrial Valves that are inspected according to ISO 15848 are labelled with the categories that have been achieved. The table on page 2 gives you an overview of possible classifications using the AS-Schneider ISO FE Type 2 as an example:

Future of ISO 15848

Currently, ISO 15848 is used mainly for process Valves. However, due to the advantages described above, there is an obvious trend towards this ISO standard

Three different sealing systems are available for the AS-Schneider ISO FE Series. Pressure Rating Class PN 420/Class 2500 applies to all the types:

AS-Schneider Type	Sealing System	Performance Data
ISO FE Type 1	FPM O-ring + Graphite Packing	Class A with 500 cycles / -29°C to 200°C Class A with 1,500 cycles / -29°C to 40°C Class B with 1,500 cycles / -29°C to 200°C
ISO FE Type 2	FPM O-ring + Graphite Packing	Class A with 1,500 cycles / -29°C to 200°C
ISO FE Type 3	PTFE / Carbon-filled PTFE	Class A with 1,500 cycles / -29°C to 40°C Class B with 1,500 cycles / -29°C to 200°C

Table: Performance data of the AS-Schneider ISO FE Series



Features of the Bellows Sealed Valves.

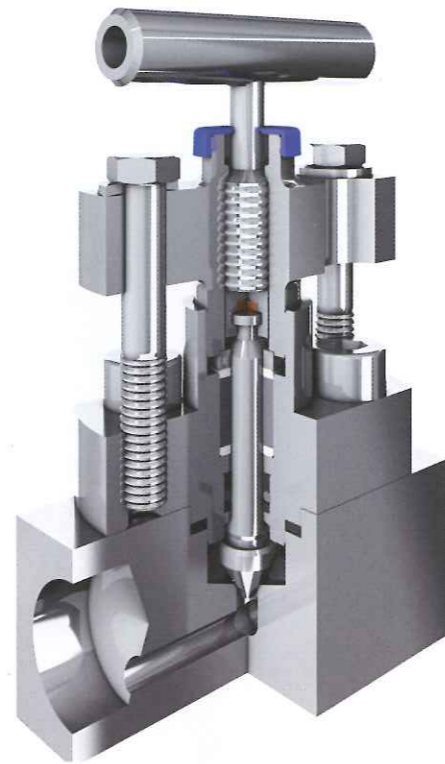

AS-Schneider Needle Valves, Monoflanges etc. with OS&Y Bolted Bonnet are equipped additionally to the general features with spring washers for compensation of thermal expansion. Pressure rating 420 bar / Class 2,500.

being applied over a wide scope to Industrial Valves for measurement and control technology. With the increased demands placed on environmental protection, we expect a considerable rise in the demand for ISO 15848 Industrial Valves over the next few years. Since initially only being used in the field of oil and gas, the ISO standard is now of increasing importance in the chemicals industry. At the moment, ISO 15848-1 is in the survey for revision. There are change requests to reduce the demanding requirements in places. The draft is available and changes for example are: The endurance class CO1 will be reduced from 500 cycles to 205 and to the tightness class "A" will be adapted by one power of ten to the level of TA-Luft. However, the AS-Schneider ISO FE Series shows that the currently demanding requirements can be achieved.

AS-Schneider ISO FE Series

AS-Schneider has several decades of experience in manufacturing high-quality sealing systems for reducing emissions like bellows upper parts or special packing systems, for example. With its ISO FE Series, AS-Schneider has developed a Valve Technology that complies

with the highest ISO15848-1 tightness class "A". With a maximum permissible leak rate of $1,3 \cdot 10^{-7}$ mbar • l/s (for a stem diameter of 7.5 mm), this class even exceeds the requirements of TA-Luft.

Type testing of the AS-Schneider ISO FE Series was carried out by TÜV Süd and lasted two weeks.

The ISO FE Series is the result of months of development and numerous tests on the company's own industrial valve test stand. The initial cause for concern was the requirement of the high pressure of 420 bar (ASME Class 2500) and the large number of switching cycles. However, by careful selection and surface treatment of the materials AS-Schneider used, they managed to get over this hurdle too.

Special properties of the AS-Schneider ISO FE Series:

- High-strength stem thread with hard coating for safe, wear-free operation.
- Non-rotating stem for low actuating forces and low wear of the sealing elements.
- Special axial bearing of the stem/ tapered connection for absorbing the highest spindle forces.
- Non-wetted parts in 316 Stainless Steel for operation in a corrosive environment.

- Sealing of the stem thread from dirt from the outside/the atmosphere.

Bellows Sealed Valves – the "technically leakproof" solution

With very hazardous media even a minimal leak rate can be too great. In cases like these, you can use tried and tested AS-Schneider Bellows Sealed Valves.

To move the valve stem upwards and downwards without leaks, a multi-layer, metal bellows is used that is welded on the one side to the stem and on the other side to the valve bonnet. Therefore a leakage along the valve stem is not possible.

Special properties of AS-Schneider Bellows Sealed Valves:

- Fully flushed, multi-layer stainless steel bellows secured against rotating, designed for 2,500 mechanical cycles
- Bellows welded on one side to stem and on other side to valve bonnet
- Non-rotating valve tip in Stellite 6 material
- Safety packing
- Available pressure classes: PN 100, PN 250, PN 400 on request.

About the author



Markus Häffner, born in Heilbronn in 1967, studied Mechanical Engineering at the University of Heilbronn. After working for 5 years in a storage system company, he changed firms and began

Pictures by: Armaturenfabrik Franz Schneider GmbH + Co. KG

working for AS-Schneider in 1998. At AS-Schneider, he initially worked as a design and development engineer and in 2001 he took over the management of this department. He is a member of several DIN standards committees such as "Industrial valves - Basic standards", "Petroleum and natural gas extraction" and "Mechanical pressure and temperature measurement devices"/"Flow and volume".

CHINA-TEJI VALVE GROUP

Featured products:
ball valve, gate valve, globe valve, check valve, butterfly valve, plug valve, flat-plate gate valve
Size: 1/2"-56"
Pressure: 150Lb-2500Lb

Address: Anfeng Ind. Zone(North Zhangbao Rd.), Oubei, Yongjia 325102, Zhejiang, P.R. China.
Tel: +86-577-67354000 67998922 Fax: +86-577-67354001
http://www.teji-valve.com E-mail: teji@teji-valve.com