

## Product Information

January 2016

AS-Schneider E Series receives Fire Safe Approval:

### Absolutely safe in case of fire

**Nordheim (Germany) – January 04, 2016 – Red hot news from AS-Schneider: The specialist for industrial valves has received the Fire Safe Approval for its E Series Valves and Manifolds – meaning that the valves offer a safe and reliable shut-off also in case of fire. The valves tested were absolutely leak-free under extreme test conditions and were still fully operational after the testing.**

Reliable fire protection is essential for industrial valves in the measurement and control technology. They are, after all, jointly responsible for safety in such sensitive applications as oil and gas installations or in the chemical and petrochemical industry. They must guarantee a reliable and safe shut-off in case of fire. This has now been certified by the TÜV SÜD with the Fire Safe Approval for the E Series Valves and Manifolds of AS-Schneider.

The Fire Safe Type Test ensures that the valves demonstrate minimal leakage and can still be operated in case of fire. During the testing, they are first placed under pressure with water and must withstand a fire for 30 minutes. Then the examiners cool down the fittings for ten minutes to below 100 degrees Celsius. Throughout the test, the leakage of the valve seat is as well as to the outside is measured. Strict limits are applied. After this, the valve must be able to be fully opened at least once.

The E Series Valves and Manifolds met these requirements with flying colours: The examiners could not identify any leakage during testing and there were no limitations in the operability of the valves after the testing. They could easily be repeatedly opened and closed. AS-Schneider

## Product Information

January 2016

manufactures the products exclusively from high quality stainless steel. Pure graphite gaskets are used for the outside sealing. This ensures that the valves function reliably even under extreme conditions.

Through the independent testing by the TÜV SÜD, AS-Schneider can now offer the E Series Valves and Manifolds as "Fire Safe Certified" – a significant advantage over solutions that have only been awarded the "Fire Safe Design". These products are also designed to operate in case of fire, but have not been officially tested. The approval applies to both the Standard Valve Head Units of the instrumentation range as well as for the OS&Y Design. In this version Belleville washers are used which compensate for the linear expansion of the individual components and thus provide more reliability at the primary shut off.

**Scope:** 2,537 characters including spaces

## Product Information

January 2016

### Captions:

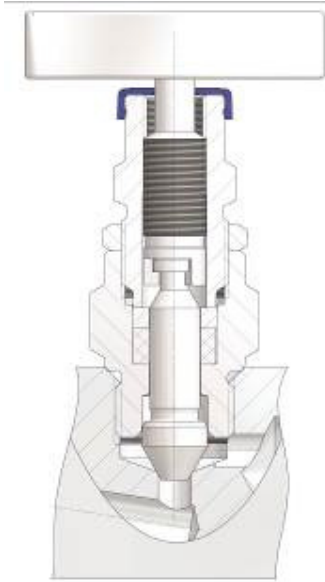

**Picture 1:** The AS-Schneider E Series Valves and Manifolds have received the Fire Safe Approval.

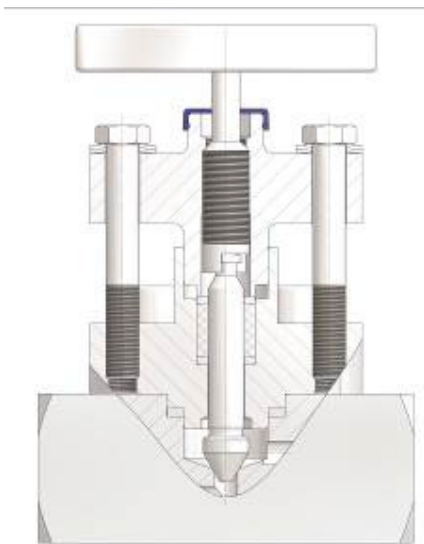

**Picture 2:** The approval applies to both the standard valve head unit of the instrumentation range as well as for the OS&Y Design.

**Pictures by:** Armaturenfabrik Franz Schneider GmbH + Co. KG

## Product Information

January 2016

### **About AS-Schneider**

The family-run company, AS-Schneider, was founded in 1875 and with over 350 employees, is one of the leading manufacturers of Instrumentation Valves and Manifolds worldwide. In the market segment for Large-Bore Diesel Engine Valves such as those used in marine propulsion and the generation of electricity, AS-Schneider is even the world market leader. With our own subsidiaries in Romania, Singapore, Dubai (UAE) and Houston (USA) and professional partners in more than 20 countries worldwide, we are located everywhere our customers need us.

### **Press contact:**

Armaturenfabrik Franz Schneider GmbH + Co. KG  
Anastassija Kinstler - Marketing and Public Relations  
Bahnhofplatz 12 - 74226 Nordheim - Deutschland/Germany  
Tel. +49 7133 101 187, Fax +49 7133 101 160  
[a.kinstler@as-schneider.com](mailto:a.kinstler@as-schneider.com), [www.as-schneider.com](http://www.as-schneider.com)